

IMX-H2401

X-Ray Single View Full Body Scanner System

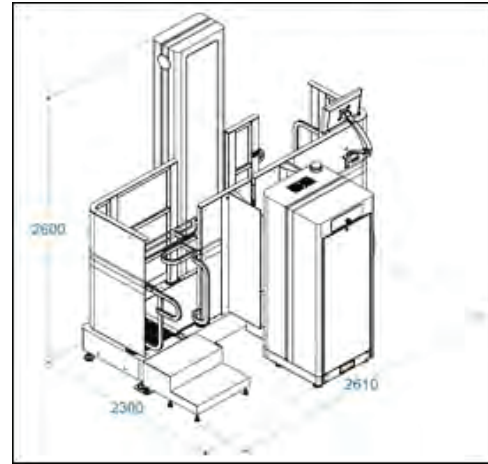

Introduction

IMX-H2401 X-Ray Dual View Full Body Scanner System applies Micro Dose X-Ray Technology to screen full body with less than 0.20 μ Sv per scan and low dose for the torso. The full body inspection system can effectively detect metallic and non-metallic contraband and threat such as weapon, explosives and drugs concealed both internal and external of the body. 3.6 seconds per scan, and more than 1000 people scanned per hour. Comprehensively detect hidden dangerous goods, drugs, liquids, contraband, etc. carried in and out of the human body, in heavy clothes, in shoes, and in prosthetics; during security inspection, it can not only inspect thoroughly, but also ensure that the privacy of the inspected is not violated; can Distinguish organics, inorganic and mixtures.

Main Features

Single View

Full body detection and torso enhancement

Micro Dose for Safety

Transmission screening in lower dose per scan:
0.15 μ Gy

Fully Shield Protection

Fully shielded lead panel design for better protection of operators and surroundings

Ultra-Fast

3.6 seconds per scan.

Autowalk Like Design

Continuously circular belt design over 1000 people per hour

Ultra Clear Image

Higher resolution with no image distortion

Applications

Law Enforcement:

prisons, police and narcotics agency

Public Transportation:

train station, ports, airports and customs

Mining & Industrial Theft:

gold mine, jewelry shop, and electronic factories

Governmental & Public Safety:

parliaments, courts, entertainment & sport events and public gatherings

Technical Specifications

Indicators	Specification
Dimension	2600mm×2300mm×2600mm (L×W×H)
Weight	1000kg
Power supply	220V AC, 50Hz±3
Single detection dose	0.15μGy
Power Consumption	800W
Working Temperature Relative Humidity	-5°C~40°C 10%~90% non-condensing.
Scanning Height	2000 mm
Leakage current inspection	0.2mA
Leakage dose rate outside the non-enclosed protective boundary	0.5meters distance away from outer. Inlet average: 0.14uGy/h, outlet average: 0.14uGy/h
Wire Detectability	AWG40
Spatial Resolution	1.0mm
Contrast Sensitivity	0.5%
Single Scan time	3.6 seconds
Throughput	≥1000 persons per hour
Sound Pressure Level	53.2dB
Security Inspection Method	Continuous cycle uninterrupted motion scan
Imaging Performance	detect hidden dangerous goods, drugs, liquids, contraband, etc. carried in and out of the human body, in heavy clothes, in shoes, and in prosthetics
Image Processing Functions	Gray scale scan, Zoom, B/W, pseudo-color
Image Retrieve	The device should be able to retrieve stored images based on parameters such as operator ID and image generation time.
Image Storage	1,000,000 pictures (support bmp, jpeg, tiff, png and other forms; support USB transmit)
Auxiliary management functions	Time and date display, inspection count, system working timing, ray beam output timing, system operation log, maintenance and diagnosis functions